

Installation Instructions

NOTE: Read the entire instruction manual before starting the installation.

SAFETY CONSIDERATIONS

Improper installation, adjustment, alteration, service, maintenance, or use can cause explosion, fire, electrical shock or other conditions which may cause personal injury or property damage. Consult a qualified installer, service agency, or your distributor or branch for information or assistance. The qualified installer or agency must use factory authorized kits or accessories when modifying products.

Follow all safety codes. Installation must be in compliance with local and national building codes. Wear safety glasses, protective clothing, and work gloves. Have fire extinguisher available. Read these instructions thoroughly and follow all warnings or cautions included in literature and attached to the unit.

Recognize safety information.

This is the safety-alert symbol . When you see this symbol on the unit and in instructions or manuals, be alert to the potential for personal injury.

These words are used with the safety-alert symbol. **DANGER** identifies the most serious hazards, which **will** result in severe personal injury or death. **WARNING** signifies a hazard, which **could** result in personal injury or death. **CAUTION** is used to identify unsafe practices, which **may** result in minor personal injury or product and property damage. **NOTE** is used to highlight suggestions which **will** result in enhanced installation, reliability, or operation.

WARNING

ELECTRICAL SHOCK HAZARD

Failure to follow this warning could result in personal injury or death.

Before beginning any installation or modification, be sure the main electrical disconnect is in the OFF position. Tag the disconnect switch with a suitable warning label.

INTRODUCTION

These instructions cover the installation of low-ambient pressure switch Part No. KSALA0201R22 and KSALA0301410 in all single-speed air conditioners or heat pumps using R-22 or R-410A. Refer to Table 1 for kit usage. This device is a long life pressure switch that maintains head pressure by turning the fan off and on. Other accessories may be required. Refer to the Required Changes for Cooling Units and Heat Pump Units section.

DESCRIPTION AND USAGE

The low-ambient pressure switch kit is a long life pressure switch which turns the fan on and off as shown in Table 1. It is wired in series with black fan lead. Sleeve-bearing motors can be used with this control.

INSTALLATION

The pressure switch is mounted inside the outdoor unit cabinet by using adapter tube supplied. The adapter tee is mounted to liquid service valve and tube is routed through one of the knockout holes in unit cabinet. From inside cabinet, the flare nut is attached to extender tube. (See Fig. 1.) The pressure switch is wired in series with black or common fan lead.

PROCEDURE 1—WIRING FOR ALL VOLTAGES OF COOLING UNITS

For all voltages of cooling units, refer to Fig. 2 and wire low-ambient pressure switch as follows:

1. Disconnect black fan lead from contactor and connect this lead to yellow or violet wire from low-ambient pressure switch using connector supplied.
2. Connect blue wire from low-ambient pressure switch to contactor terminal from which black fan lead was removed.

PROCEDURE 2—WIRING FOR HEAT PUMPS

Heat pumps require a normally closed isolation relay with the 24-v coil connected to the C and O terminals of defrost board.

A. 208/230v Applications

For 208/230-v heat pump applications, refer to Fig. 3 and wire low-ambient pressure switch as follows:

1. Remove black fan lead from defrost board terminal OF2 and reconnect it to NC terminal of isolation relay. Connect yellow or violet lead from low-ambient pressure switch to same NC terminal of isolation relay.
2. Connect a wire from the other NC terminal of isolation relay to OF2 terminal of defrost board. Connect blue lead from low-ambient pressure switch to same NC terminal of isolation relay.

B. 460v Applications

For 460-v heat pump applications, refer to Fig. 4 and wire low-ambient pressure switch as follows:

1. Remove black fan lead from outdoor fan relay terminal number 3 and reconnect it to NC terminal of isolation relay. Connect yellow or violet lead from low-ambient pressure switch to same NC terminal of isolation relay.
2. Connect a wire from outdoor fan relay terminal number 3 to other NC terminal of isolation relay. Connect blue lead from low-ambient pressure switch to same NC terminal of isolation relay.

Table 1—Kit Usage and Cut In/Cut Out Pressures

KIT PART NO.	REFRIGERANT	PRESSURE SWITCH CLOSSES (PSIG)	PRESSURE SWITCH OPENS (PSIG)	WIRE COLORS
KSALA0201R22	R-22	225	100	Blue and Yellow
KSALA0301410	R-410A	365	200	Blue and Violet

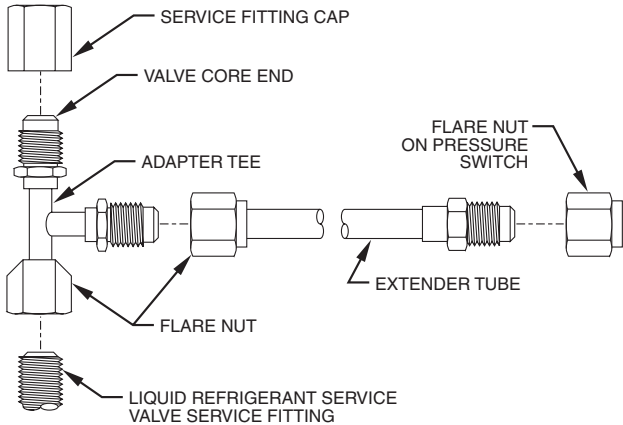

Fig. 1 — Low-Ambient Pressure Switch

A00025

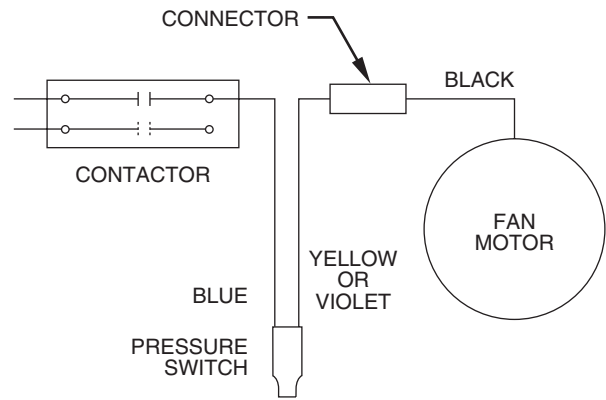

Fig. 2 — Power Wiring for All Voltages of Cooling Applications

A97326

REQUIRED CHANGES FOR COOLING UNITS AND HEAT PUMP UNITS

1. Crankcase heaters are required on all applications where low-ambient controls are used.
2. Start capacitor and relay (hard start) kits are required on all single-phase applications where low-ambient controls are used.
3. Evaporator freeze thermostat KAAFT0101AAA is required on all applications where low-ambient controls are used.
4. Wind baffles are required for temperatures below 0°F or where there is substantial wind.

NOTE: When wind baffles are used, raising unit off of pad a minimum of 4 in. is required to provide better airflow for moderate- and high-ambient temperatures. Check pre-sale literature for available support feet or unit risers.

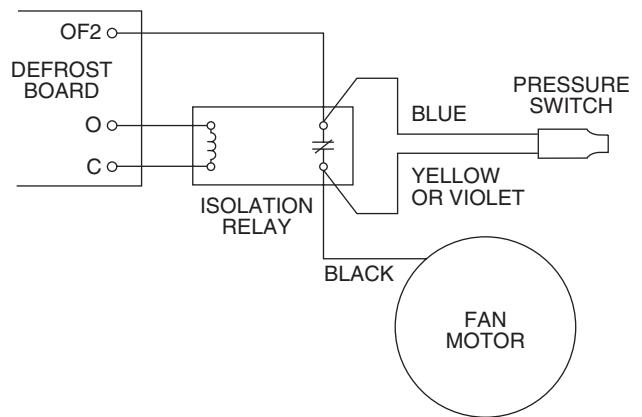

Fig. 3 — Power Wiring for 208/230v Heat Pump Applications

A97327

⚠ CAUTION

CUT HAZARD

Failure to follow this caution could result in personal injury.

To reduce risk of personal injury, wear personal protective equipment when working with wind baffles. Only experienced technicians should fabricate and install wind baffles.

5. For cooling applications only, winter start control KAAWS0101AAA must be used where low-pressure switch tripping may be encountered. Winter start control must be wired in parallel with low-pressure switch. This allows a delay of 3 minutes before low-pressure switch becomes part of control circuit. (See Fig. 5.)

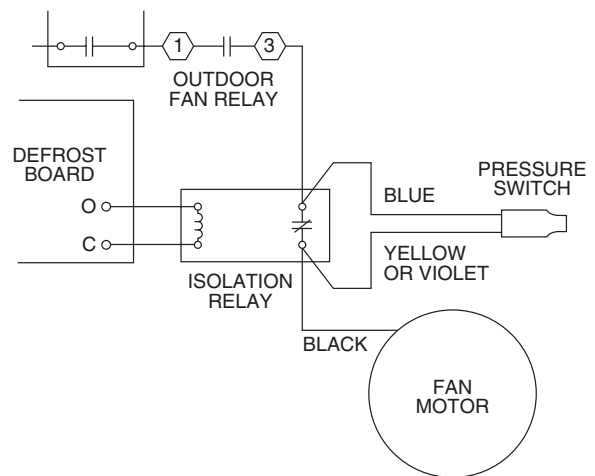
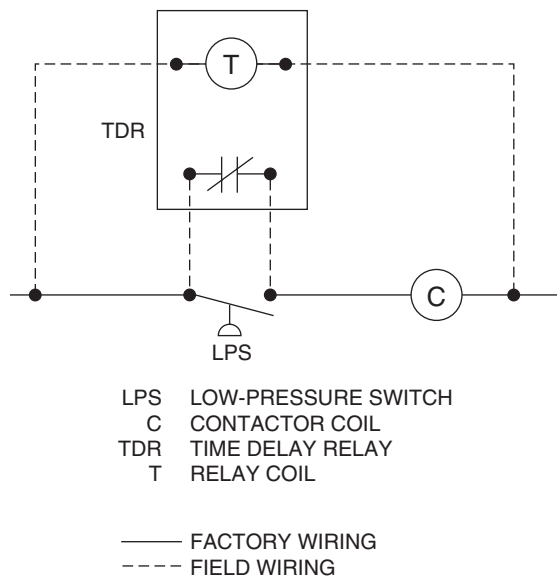

Fig. 4 — Power Wiring for 460v Heat Pump Applications

A97328

KSALA



A93165

Fig. 5 — Low Voltage Wiring for Winter Start Control

START-UP

To start units equipped with the low-ambient pressure switch, perform the following steps:

1. Turn power on to unit.
2. Set thermostat below room temperature.
3. Wait for the unit to start. There may be a 5-minute delay in the thermostat or in the outdoor unit.
4. Observe unit operation as described below.
 - a. The fan will be off when compressor starts.
 - b. At outdoor temperatures around 0°F, fan may not run at all.
 - c. At summer temperatures, fan will start after 10 to 30 sec of compressor operation and may not turn off until thermostat is satisfied.
 - d. At outdoor ambients between 80°F and 20°F, fan will turn on and off to maintain pressure as shown in Table 1.

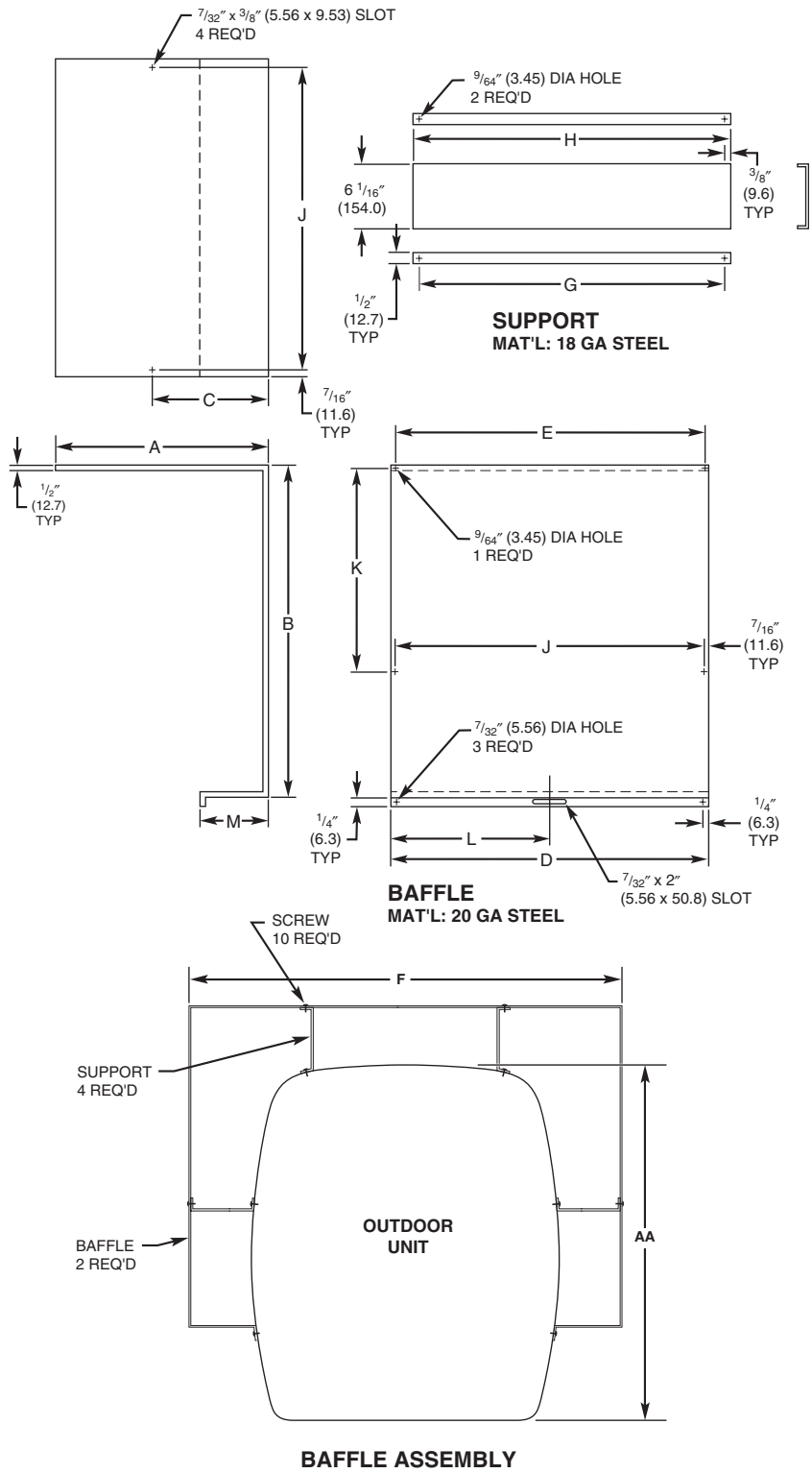

Fig. 6 — Carrier WeatherMaker® Units

A95444

**Wind Baffle Dimensions for Carrier WeatherMaker Units—38TKB, 38TKW, 38YKC
(In.)**

Unit Size	AA	Unit Height	A	B	C	D	E	F	G	H	J	K	L	M
Small	27-1/2	21-7/8	17	25-1/4	10-3/8	19-3/4	20-1/2	34	19-11/16	20-7/16	19-5/8	0	0	6-1/8
		25-7/8	17	25-1/4	10-3/8	23-3/4	24-1/2	34	23-11/16	24-7/16	23-5/8	0	11-7/8	6-1/8
		31-7/8	17	25-1/4	10-3/8	29-3/4	30-1/2	34	29-11/16	30-7/16	29-5/8	0	14-7/8	6-1/8
Medium	34-15/16	25-7/8	21	32	11-3/16	23-3/4	24-1/2	42	23-11/16	24-7/16	23-5/8	19-11/16	11-7/8	6-11/16
		31-7/8	21	32	11-3/16	29-3/4	30-1/2	42	29-11/16	30-7/16	29-5/8	19-11/16	14-7/8	6-11/16
		37-7/8	21	32	11-3/16	35-3/4	36-1/2	42	35-11/16	36-7/16	35-5/8	19-11/16	17-7/8	6-11/16
Large	45	31-7/8	25-3/16	42	12-15/16	29-3/4	30-1/2	50-7/16	29-11/16	30-7/16	29-5/8	22-11/16	14-7/8	7-1/16
		37-7/8	25-3/16	42	15-15/16	35-3/4	36-1/2	50-7/16	35-11/16	36-7/16	35-5/8	22-11/16	17-7/8	7-1/16

**Wind Baffle Dimensions for Carrier WeatherMaker Units with Silencer System Top
(In.)**

Unit Size	AA	Unit Height	A	B	C	D	E	F	G	H	J	K	L	M
Small	27-1/2	23-13/16	17	25-1/4	10-3/8	19-3/4	20-1/2	34	19-11/16	20-7/16	19-5/8	0	0	6-1/8
		27-13/16	17	25-1/4	10-3/8	23-3/4	24-1/2	34	23-11/16	24-7/16	23-5/8	0	11-7/8	6-1/8
		33-13/16	17	25-1/4	10-3/8	29-3/4	30-1/2	34	29-11/16	30-7/16	29-5/8	0	14-7/8	6-1/8
Medium	34-15/16	27-13/16	21	32	11-3/16	23-3/4	24-1/2	42	23-11/16	24-7/16	23-5/8	19-11/16	11-7/8	6-11/16
		33-13/16	21	32	11-3/16	29-3/4	30-1/2	42	29-11/16	30-7/16	29-5/8	19-11/16	14-7/8	6-11/16
		39-13/16	21	32	11-3/16	35-3/4	36-1/2	42	35-11/16	36-7/16	35-5/8	19-11/16	17-7/8	6-11/16
Large	45	33-13/16	25-3/16	42	12-15/16	29-3/4	30-1/2	50-7/16	29-11/16	30-7/16	29-5/8	22-11/16	14-7/8	7-1/16
		39-13/16	25-3/16	42	15-15/16	35-3/4	36-1/2	50-7/16	35-11/16	36-7/16	35-5/8	22-11/16	17-7/8	7-1/16

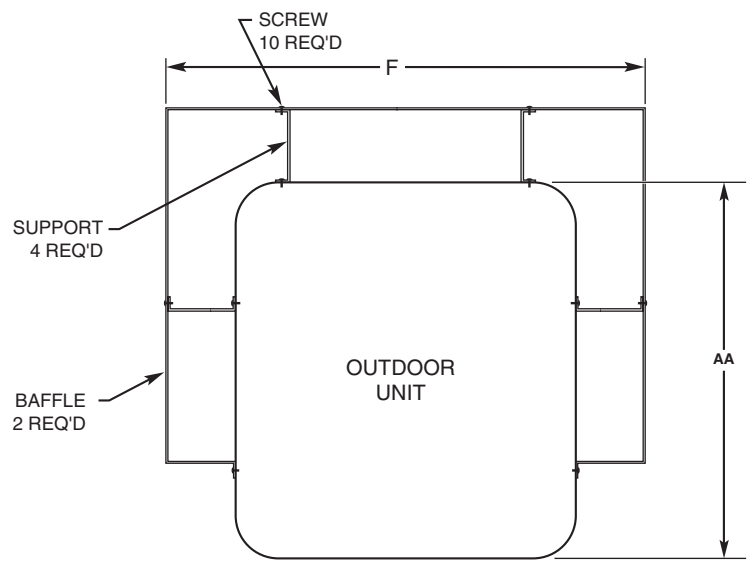
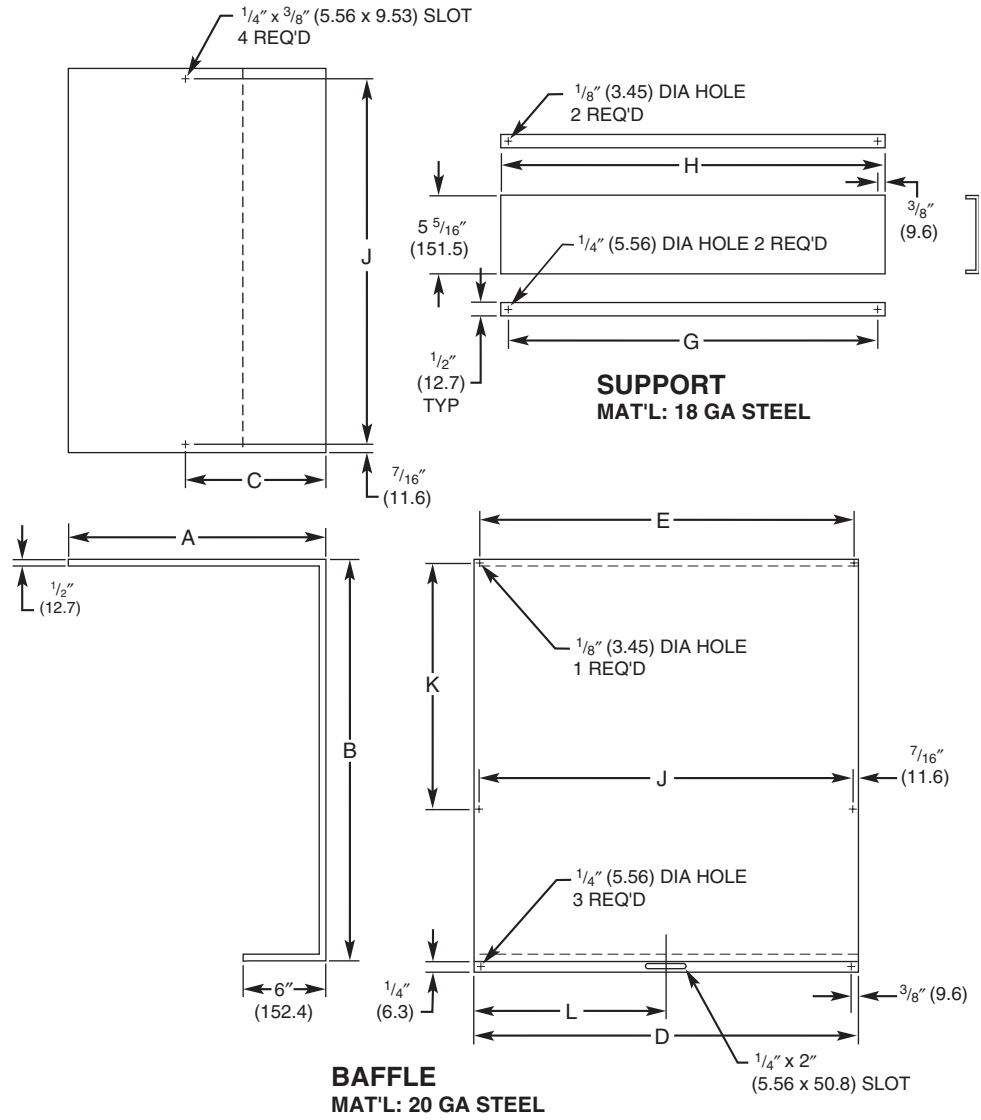

Fig. 7 – Bryant Reliant® Units

**Wind Baffle Dimensions for 10 Seer Bryant Reliant Units with Star-Burst Top
(In.)**

Unit Size	AA	Unit Height	A	B	C	D	E	F	G	H	J	K	L
Small	26-3/16	21-7/8	17-1/4	24-5/16	10-1/4	19-3/4	20-1/2	34-1/2	19-5/8	20-3/8	19-5/8	0	0
		25-7/8	17-1/4	24-5/16	10-1/4	23-3/4	24-1/2	34-1/2	23-5/8	24-3/8	23-5/8	0	11-7/8
		31-7/8	17-1/4	24-5/16	10-1/4	29-3/4	30-1/2	34-1/2	29-5/8	30-3/8	29-5/8	0	14-7/8
Medium	33	25-7/8	21	30-5/8	10-1/4	23-3/4	24-1/2	42	23-5/8	24-3/8	23-5/8	17-1/8	11-7/8
		31-7/8	21	30-5/8	10-1/4	29-3/4	30-1/2	42	29-5/8	30-3/8	29-5/8	17-1/8	14-7/8
		37-7/8	21	30-5/8	10-1/4	35-3/4	36-1/2	42	35-5/8	36-3/8	35-5/8	17-1/8	17-7/8
Large	42-1/16	31-7/8	25-5/16	39-3/4	10-1/4	29-3/4	30-1/2	50-9/16	29-5/8	30-3/8	29-5/8	21-11/16	14-7/8
		37-7/8	25-5/16	39-3/4	10-1/4	35-3/4	36-1/2	50-9/16	35-5/8	36-3/8	35-5/8	21-11/16	17-7/8

**Wind Baffle Dimensions for Bryant Reliant Units with AeroQuiet Top
(In.)**

Unit Size	AA	Unit Height	A	B	C	D	E	F	G	H	J	K	L
Small	26-3/16	23-13/16	17-1/4	24-5/16	10-1/4	19-3/4	20-1/2	34-1/2	19-5/8	20-3/8	19-5/8	0	0
		27-13/16	17-1/4	24-5/16	10-1/4	23-3/4	24-1/2	34-1/2	23-5/8	24-3/8	23-5/8	0	11-7/8
		33-13/16	17-1/4	24-5/16	10-1/4	29-3/4	30-1/2	34-1/2	29-5/8	30-3/8	29-5/8	0	14-7/8
Medium	33	27-13/16	21	30-5/8	10-1/4	23-3/4	24-1/2	42	23-5/8	24-3/8	23-5/8	17-1/8	11-7/8
		33-13/16	21	30-5/8	10-1/4	29-3/4	30-1/2	42	29-5/8	30-3/8	29-5/8	17-1/8	14-7/8
		39-13/16	21	30-5/8	10-1/4	35-3/4	36-1/2	42	35-5/8	36-3/8	35-5/8	17-1/8	17-7/8
Large	42-1/16	33-13/16	25-5/16	39-3/4	10-1/4	29-3/4	30-1/2	50-9/16	29-5/8	30-3/8	29-5/8	21-11/16	14-7/8
		39-13/16	25-5/16	39-3/4	10-1/4	35-3/4	36-1/2	50-9/16	35-5/8	36-3/8	35-5/8	21-11/16	17-7/8



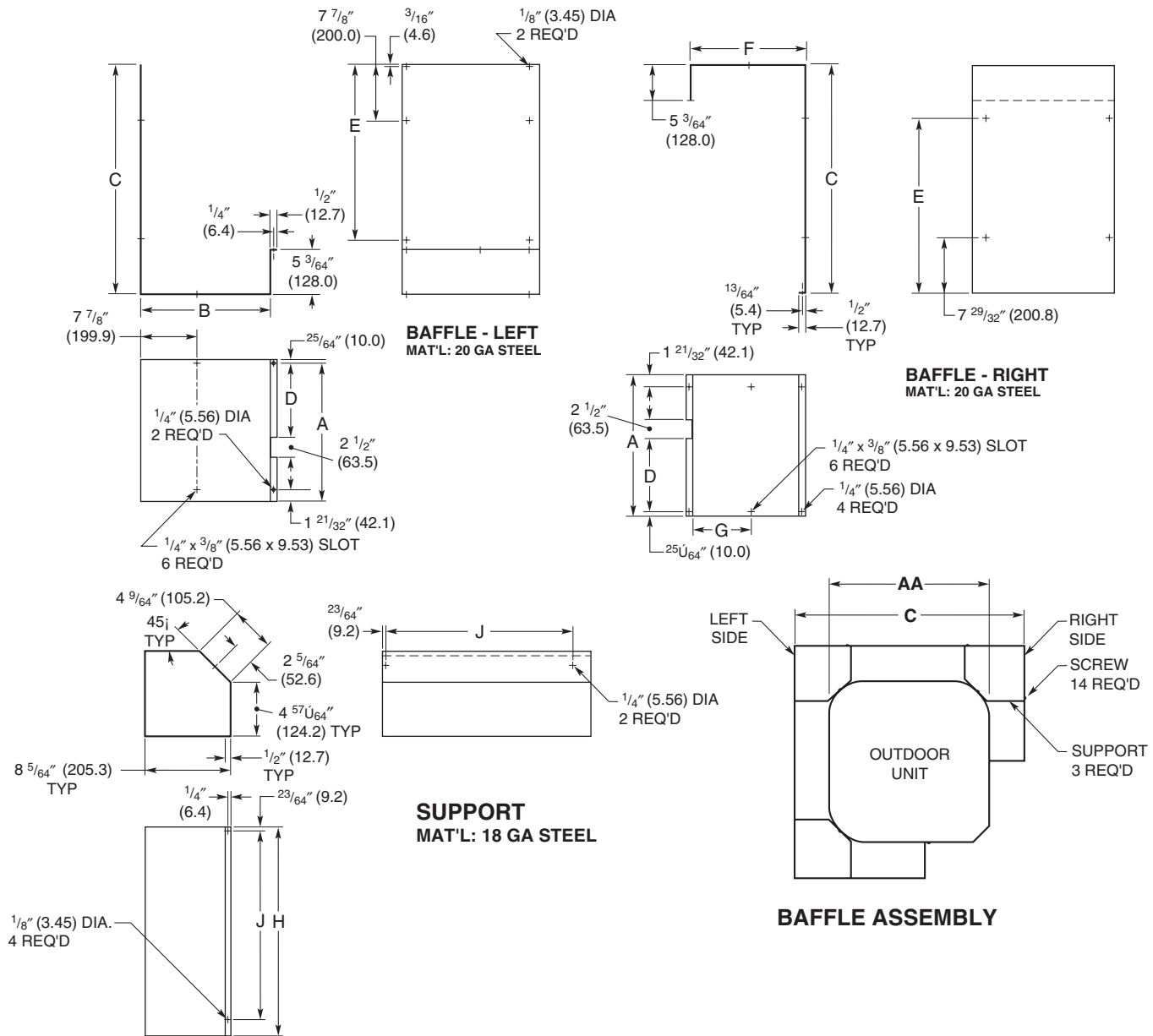

Fig. 8 – Carrier / Bryant / Payne Cube Units with 3/8" Coil Tubing

A95446

**Wind Baffle Dimensions for Carrier / Bryant / Payne Cube Units with 3/8" Coil Tubing
(In.)**

Unit Size	AA	Unit Height	A	B	C	D	E	F	G	H	J	
Small	18	21-15/16	19-7/8	13-3/4	28-1/8	10-11/16	20-1/4	11-11/16	3-13/16	19-13/16	17-13/16	
		23-15/16	21-7/8	13-3/4	28-1/8	10-11/16	20-1/4	11-11/16	3-13/16	21-13/16	19-13/16	
		25-15/16	23-7/8	13-3/4	28-1/8	10-11/16	20-1/4	11-11/16	3-13/16	3-13/16	23-13/16	21-13/16
		27-15/16	25-7/8	13-3/4	28-1/8	10-11/16	20-1/4	11-11/16	3-13/16	3-13/16	25-13/16	23-13/16
		29-15/16	27-7/8	13-3/4	28-1/8	10-11/16	20-1/4	11-11/16	3-13/16	3-13/16	27-13/16	25-13/16
		31-15/16	29-7/8	13-3/4	28-1/8	10-11/16	20-1/4	11-11/16	3-13/16	3-13/16	29-13/16	27-13/16
		33-15/16	31-7/8	13-3/4	28-1/8	10-11/16	20-1/4	11-11/16	3-13/16	3-13/16	31-13/16	29-13/16
		21-15/16	19-7/8	18-5/16	32-5/8	10-11/16	24-3/4	16-3/16	8-1/4	8-1/4	19-13/16	17-13/16
		23-15/16	21-7/8	18-5/16	32-5/8	10-11/16	24-3/4	16-3/16	8-1/4	8-1/4	21-13/16	19-13/16
		25-15/16	23-7/8	18-5/16	32-5/8	10-11/16	24-3/4	16-3/16	8-1/4	8-1/4	23-13/16	21-13/16
Medium	22-1/2	27-15/16	25-7/8	18-5/16	32-5/8	10-11/16	24-3/4	16-3/16	8-1/4	25-13/16	23-13/16	
		29-15/16	27-7/8	18-5/16	32-5/8	10-11/16	24-3/4	16-3/16	8-1/4	27-13/16	25-13/16	
		31-15/16	29-7/8	18-5/16	32-5/8	10-11/16	24-3/4	16-3/16	8-1/4	29-13/16	27-13/16	
		33-15/16	31-7/8	18-5/16	32-5/8	10-11/16	24-3/4	16-3/16	8-1/4	31-13/16	29-13/16	
		37-15/16	33-7/8	18-5/16	32-5/8	10-11/16	24-3/4	16-3/16	8-1/4	33-13/16	31-13/16	
		39-15/16	35-7/8	18-5/16	32-5/8	10-11/16	24-3/4	16-3/16	8-1/4	35-13/16	33-13/16	
		25-15/16	23-7/8	25-3/4	40-1/8	10-11/16	32-1/4	23-11/16	15-13/16	15-13/16	23-13/16	21-13/16
		27-15/16	25-7/8	25-3/4	40-1/8	10-11/16	32-1/4	23-11/16	15-13/16	15-13/16	25-13/16	23-13/16
		29-15/16	27-7/8	25-3/4	40-1/8	10-11/16	32-1/4	23-11/16	15-13/16	15-13/16	27-13/16	25-13/16
		31-15/16	29-7/8	25-3/4	40-1/8	10-11/16	32-1/4	23-11/16	15-13/16	15-13/16	29-13/16	27-13/16
Large	30	33-15/16	31-7/8	25-3/4	40-1/8	10-11/16	32-1/4	23-11/16	15-13/16	31-13/16	29-13/16	
		35-15/16	33-7/8	25-3/4	40-1/8	10-11/16	32-1/4	23-11/16	15-13/16	33-13/16	31-13/16	
		37-15/16	35-7/8	25-3/4	40-1/8	10-11/16	32-1/4	23-11/16	15-13/16	35-13/16	33-13/16	
		39-15/16	37-7/8	25-3/4	40-1/8	10-11/16	32-1/4	23-11/16	15-13/16	37-13/16	35-13/16	
		43-15/16	41-7/8	25-3/4	40-1/8	10-11/16	32-1/4	23-11/16	15-13/16	41-13/16	39-13/16	

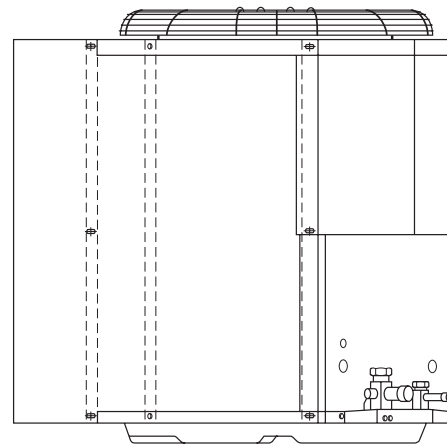
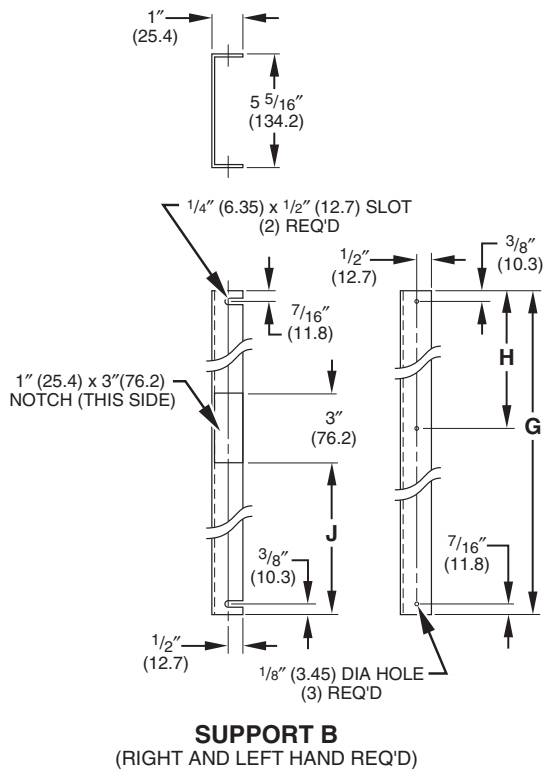
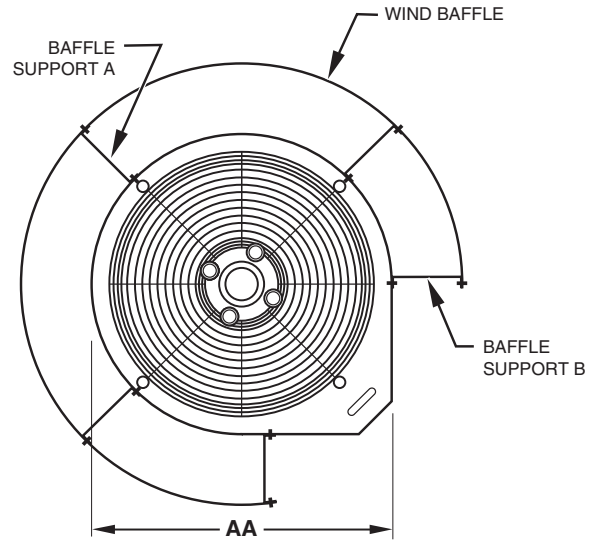
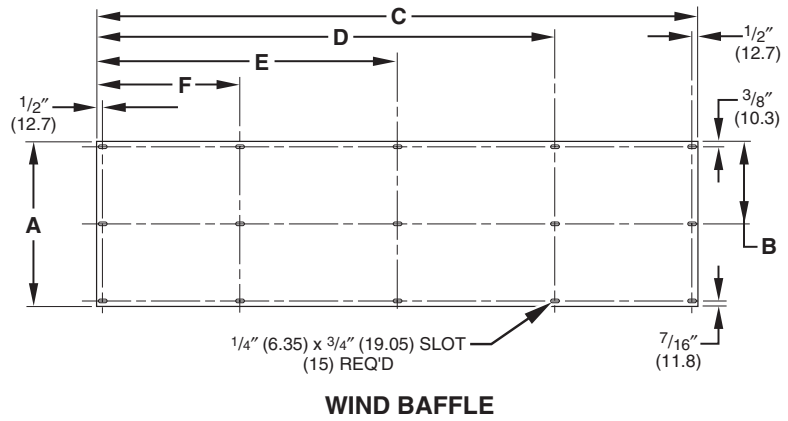
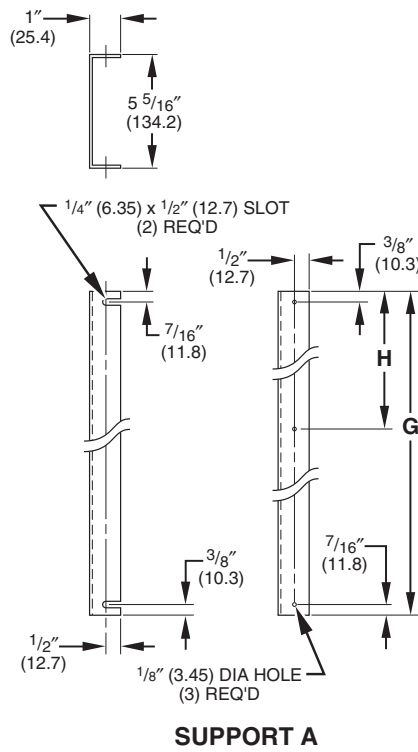

Fig. 9 – Payne Units—Models PA10 / PA12 and PH10 / PH12

A95447

**Wind Baffle Dimensions for Payne Model PA10 / PA12 Air Conditioning Units
(In.)**

Unit Size	AA	Unit Height	A	B	C	D	E	F	G	H	J
Medium	22-1/2	21-15/16	18-11/16	9-5/16	81-1/2	67-7/8	41-13/16	15-13/16	18-11/16	9-5/16	10-13/16
		23-15/16	20-11/16	10-5/16	81-1/2	67-7/8	41-13/16	15-13/16	18-11/16	10-5/16	10-13/16
		25-15/16	22-11/16	11-5/16	81-1/2	67-7/8	41-13/16	15-13/16	18-11/16	11-5/16	10-13/16
		27-15/16	24-11/16	12-5/16	81-1/2	67-7/8	41-13/16	15-13/16	18-11/16	12-5/16	10-13/16
		29-15/16	26-11/16	13-5/16	81-1/2	67-7/8	41-13/16	15-13/16	18-11/16	13-5/16	10-13/16
		31-15/16	28-11/16	14-5/16	81-1/2	67-7/8	41-13/16	15-13/16	18-11/16	14-5/16	10-13/16
		33-15/16	30-11/16	15-5/16	81-1/2	67-7/8	41-13/16	15-13/16	18-11/16	15-5/16	10-13/16
		23-15/16	20-11/16	10-5/16	107-1/16	86-9/16	54-11/16	22-3/4	24-11/16	10-5/16	10-13/16
		25-15/16	22-11/16	11-5/16	107-1/16	86-9/16	54-11/16	22-3/4	24-11/16	11-5/16	10-13/16
		27-15/16	24-11/16	12-5/16	107-1/16	86-9/16	54-11/16	22-3/4	24-11/16	12-5/16	10-13/16
Large	30	29-15/16	26-11/16	13-5/16	107-1/16	86-9/16	54-11/16	22-3/4	24-11/16	13-5/16	10-13/16
		31-15/16	28-11/16	14-5/16	107-1/16	86-9/16	54-11/16	22-3/4	24-11/16	14-5/16	10-13/16
		33-15/16	30-11/16	15-5/16	107-1/16	86-9/16	54-11/16	22-3/4	24-11/16	15-5/16	10-13/16
		35-15/16	32-11/16	16-5/16	107-1/16	86-9/16	54-11/16	22-3/4	24-11/16	16-5/16	10-13/16
		37-15/16	34-11/16	17-5/16	107-1/16	86-9/16	54-11/16	22-3/4	24-11/16	17-5/16	10-13/16
		37-15/16	36-11/16	18-5/16	107-1/16	86-9/16	54-11/16	22-3/4	24-11/16	18-5/16	10-13/16

**Wind Baffle Dimensions for Payne PH10 / PH12 Heat Pump Units
(In.)**

Unit Size	AA	Unit Height	A	B	C	D	E	F	G	H	J
Medium	22-1/2	21-15/16	18-11/16	9-5/16	81-1/2	67-7/8	41-13/16	15-13/16	18-11/16	9-5/16	14-13/16
		23-15/16	20-11/16	10-5/16	81-1/2	67-7/8	41-13/16	15-13/16	18-11/16	10-5/16	14-13/16
		25-15/16	22-11/16	11-5/16	81-1/2	67-7/8	41-13/16	15-13/16	18-11/16	11-5/16	14-13/16
		27-15/16	24-11/16	12-5/16	81-1/2	67-7/8	41-13/16	15-13/16	18-11/16	12-5/16	14-13/16
		29-15/16	26-11/16	13-5/16	81-1/2	67-7/8	41-13/16	15-13/16	18-11/16	13-5/16	14-13/16
		31-15/16	28-11/16	14-5/16	81-1/2	67-7/8	41-13/16	15-13/16	18-11/16	14-5/16	14-13/16
		33-15/16	30-11/16	15-5/16	81-1/2	67-7/8	41-13/16	15-13/16	18-11/16	15-5/16	14-13/16
		23-15/16	20-11/16	10-5/16	107-1/16	86-9/16	54-11/16	22-3/4	24-11/16	10-5/16	14-13/16
		25-15/16	22-11/16	11-5/16	107-1/16	86-9/16	54-11/16	22-3/4	24-11/16	11-5/16	14-13/16
		27-15/16	24-11/16	12-5/16	107-1/16	86-9/16	54-11/16	22-3/4	24-11/16	12-5/16	14-13/16
Large	30	29-15/16	26-11/16	13-5/16	107-1/16	86-9/16	54-11/16	22-3/4	24-11/16	13-5/16	14-13/16
		31-15/16	28-11/16	14-5/16	107-1/16	86-9/16	54-11/16	22-3/4	24-11/16	14-5/16	14-13/16
		33-15/16	30-11/16	15-5/16	107-1/16	86-9/16	54-11/16	22-3/4	24-11/16	15-5/16	14-13/16
		35-15/16	32-11/16	16-5/16	107-1/16	86-9/16	54-11/16	22-3/4	24-11/16	16-5/16	14-13/16
		37-15/16	34-11/16	17-5/16	107-1/16	86-9/16	54-11/16	22-3/4	24-11/16	17-5/16	14-13/16
		37-15/16	36-11/16	18-5/16	107-1/16	86-9/16	54-11/16	22-3/4	24-11/16	18-5/16	14-13/16



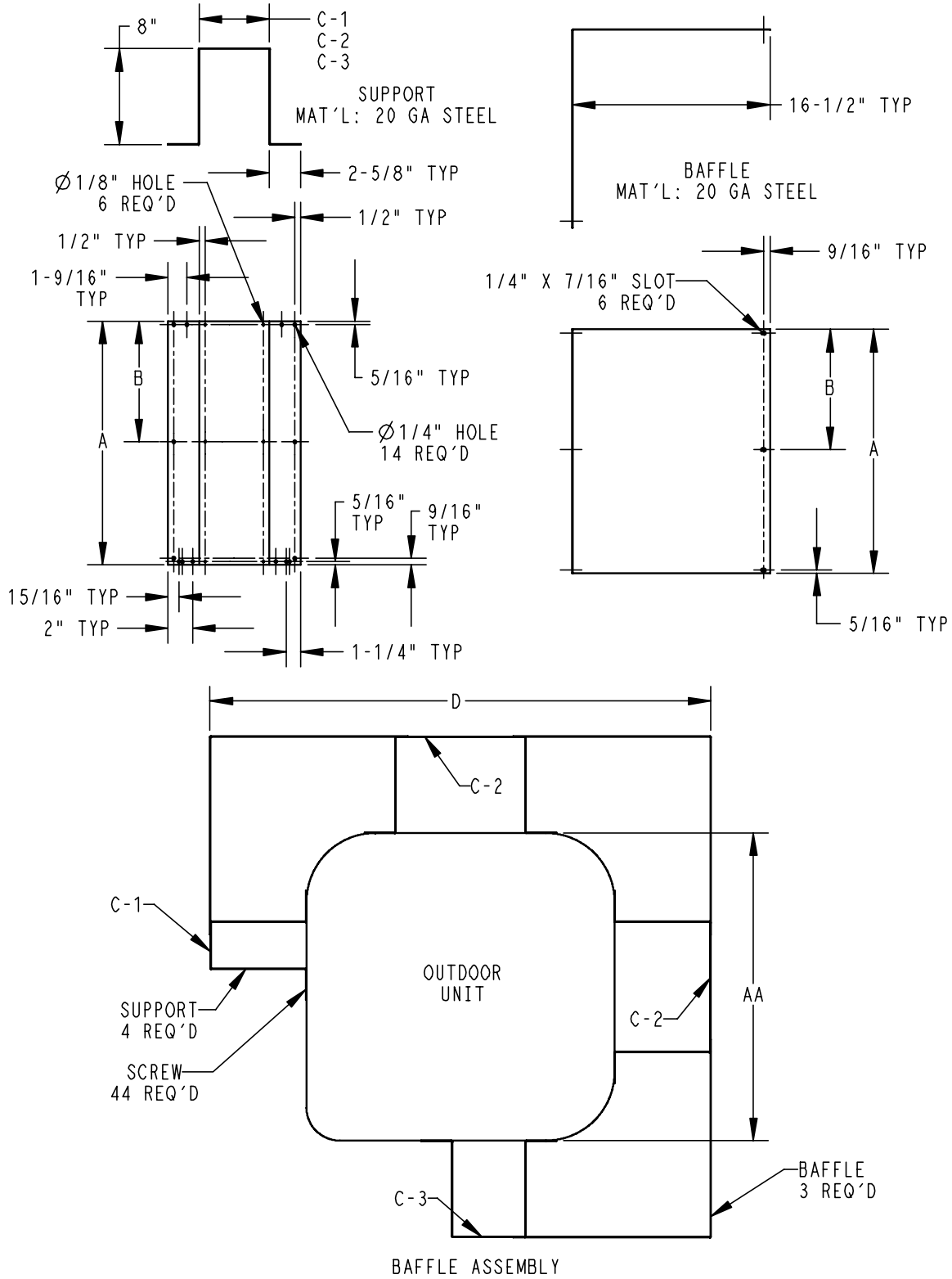
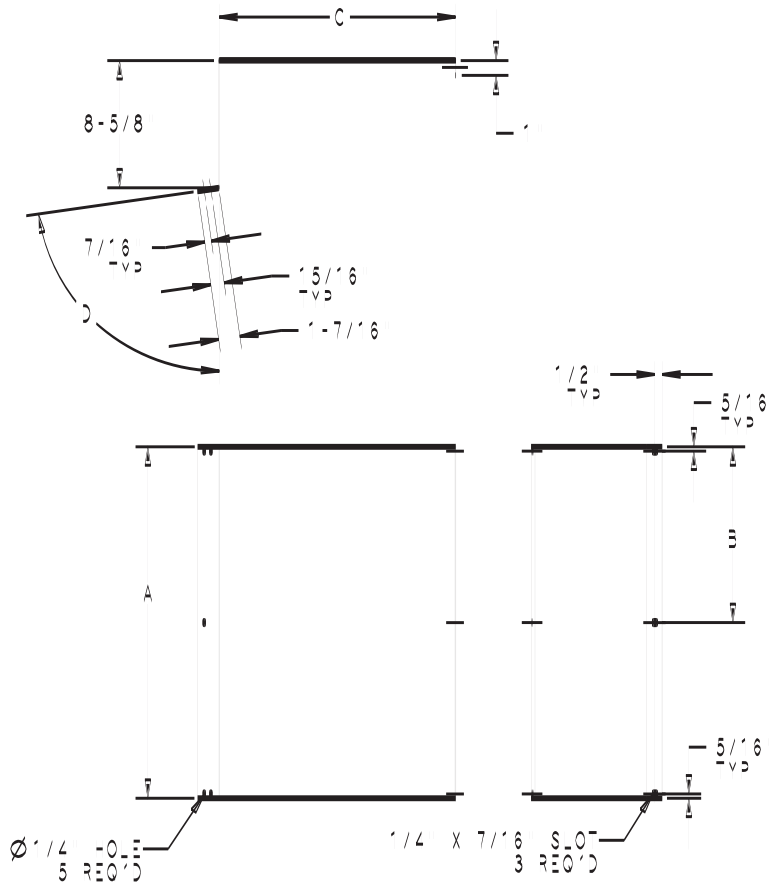

Fig. 10 – Base / Comfort™ / Legacy™ Units Baffle Assembly

A06235

**Wind Baffle Dimensions for Base / Comfort™ / Legacy™ Units
(In.)**

Unit Size	AA	Unit Height	A	B	C-1	C-2	C-3	D
Small	25-3/4	25	20-3/8	10-1/16	3-15/16	10-7/8	6-1/8	41-7/8
		28-7/16	23-13/16	11-3/4	3-15/16	10-7/8	6-1/8	41-7/8
		31-13/16	27-3/16	13-1/2	3-15/16	10-7/8	6-1/8	41-7/8
		35-1/4	30-5/8	15-3/16	3-15/16	10-7/8	6-1/8	41-7/8
		38-5/8	34	16-7/8	3-15/16	10-7/8	6-1/8	41-7/8
		42	37-3/8	18-9/16	3-15/16	10-7/8	6-1/8	41-7/8
		45-7/16	40-13/16	20-1/4	3-15/16	10-7/8	6-1/8	41-7/8
		25-1/2	20-3/8	10-1/16	9-3/8	16-5/16	11-9/16	47-3/8
		28-15/16	23-13/16	11-3/4	9-3/8	16-5/16	11-9/16	47-3/8
		32-5/16	27-3/16	13-1/2	9-3/8	16-5/16	11-9/16	47-3/8
Medium	31-1/4	35-3/4	30-5/8	15-3/16	9-3/8	16-5/16	11-9/16	47-3/8
		39-1/8	34	16-7/8	9-3/8	16-5/16	11-9/16	47-3/8
		42-1/2	37-3/8	18-9/16	9-3/8	16-5/16	11-9/16	47-3/8
		45-15/16	40-13/16	20-1/4	9-3/8	16-5/16	11-9/16	47-3/8
		25-1/2	20-3/8	10-1/16	13-3/16	20-1/8	15-3/8	51-1/8
		28-15/16	23-13/16	11-3/4	13-3/16	20-1/8	15-3/8	51-1/8
Large	35	32-5/16	27-3/16	13-1/2	13-3/16	20-1/8	15-3/8	51-1/8
		35-3/4	30-5/8	15-3/16	13-3/16	20-1/8	15-3/8	51-1/8
		39-1/8	34	16-7/8	13-3/16	20-1/8	15-3/8	51-1/8
		42-1/2	37-3/8	18-9/16	13-3/16	20-1/8	15-3/8	51-1/8
		45-15/16	40-13/16	20-1/4	13-3/16	20-1/8	15-3/8	51-1/8
		25-1/2	20-3/8	10-1/16	13-3/16	20-1/8	15-3/8	51-1/8
		28-15/16	23-13/16	11-3/4	13-3/16	20-1/8	15-3/8	51-1/8



A06231

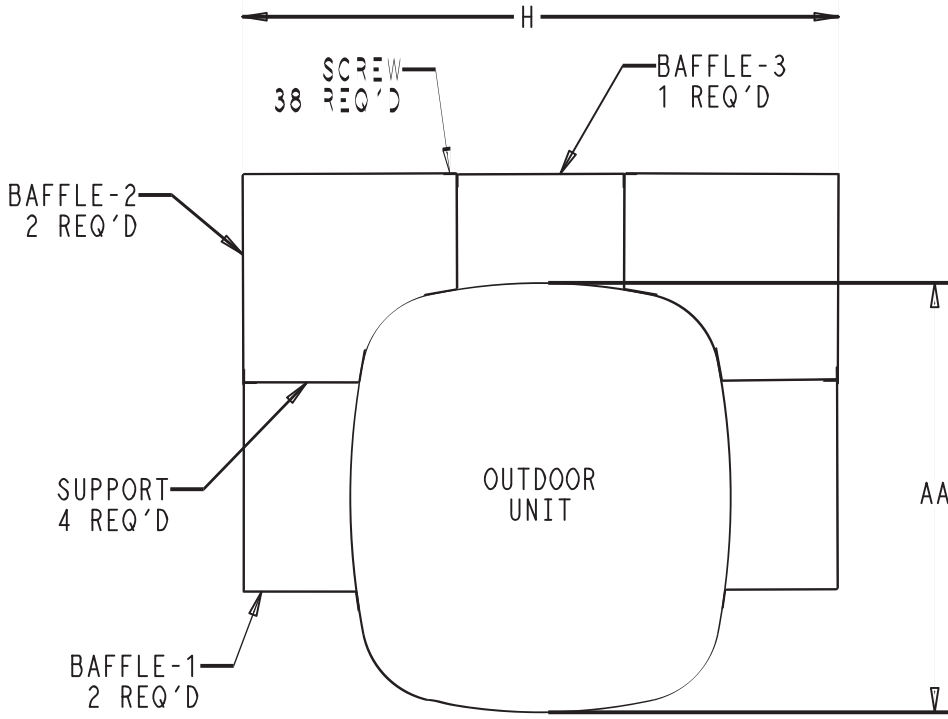

BAFFLE ASSEMBLY

Fig. 11 – Performance™ and Preferred™ Series Baffle Assemblies

A06230

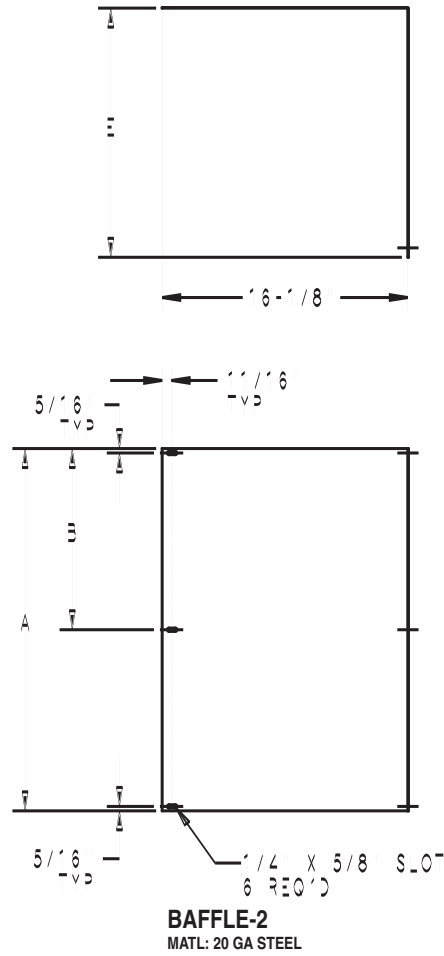

A06232

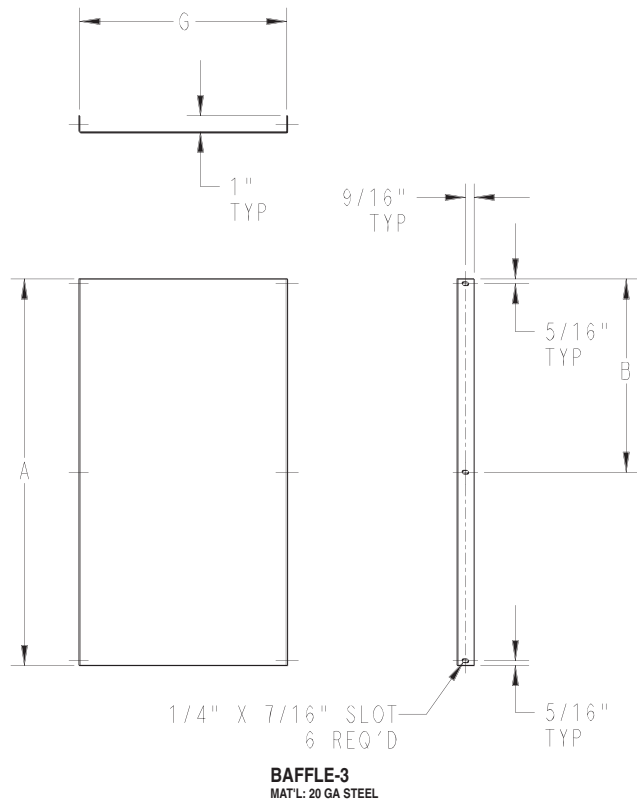
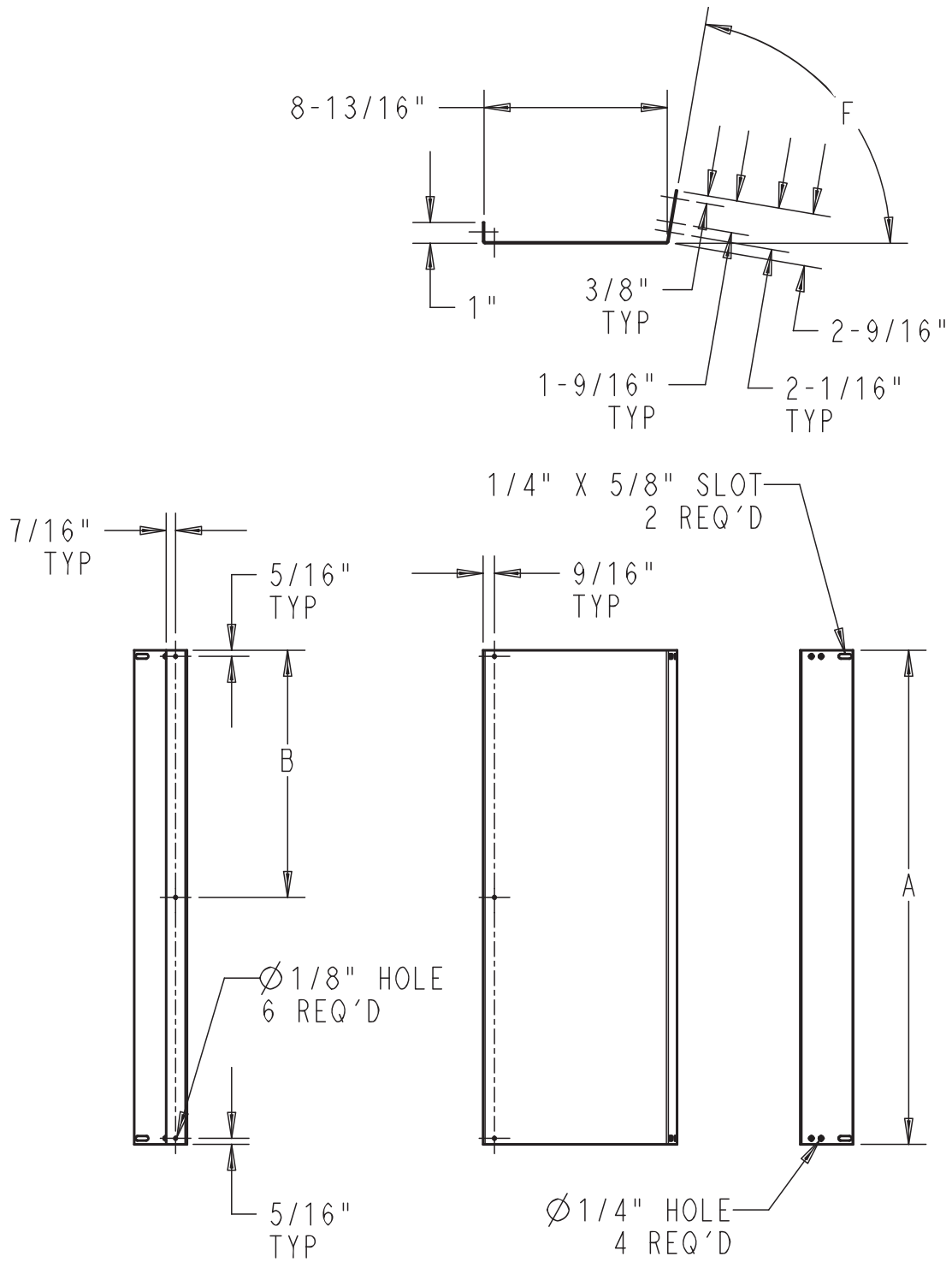

Fig. 12 – Performance™ and Preferred™ Series Baffle Assemblies (continued)

A06234



SUPPORT
MAT'L: 20 GA STEEL

Fig. 13 – Performance™ and Preferred™ Series Baffle Assemblies (continued)

Wind Baffle Dimensions for Performance™ Series Units

Unit Size	AA	Unit Height	A (In.)	B (In.)	C (In.)	D (degrees)	E (In.)	F (degrees)	G (In.)	H (In.)
Medium	33	29-1/2	23-13/16	11-7/8	16	81.9	16-3/8	80.3	12-3/4	45-7/8
		32-15/16	27-3/16	13-5/8	16	81.9	16-3/8	80.3	12-3/4	45-7/8
		36-5/16	30-5/8	15-5/16	16	81.9	16-3/8	80.3	12-3/4	45-7/8
		39-3/4	34	17	16	81.9	16-3/8	80.3	12-3/4	45-7/8
		43-1/8	37-3/8	18-11/16	16	81.9	16-3/8	80.3	12-3/4	45-7/8
	46-1/2	40-13/16	20-3/8	16	81.9	16-3/8	80.3	12-3/4	45-7/8	
	32-15/16	23-13/16	11-7/8	22-5/16	80.2	16-11/16	78.8	17-3/8	51-1/16	
	36-3/8	27-3/16	13-5/8	22-5/16	80.2	16-11/16	78.8	17-3/8	51-1/16	
	39-3/4	30-5/8	15-5/16	22-5/16	80.2	16-11/16	78.8	17-3/8	51-1/16	
	43-3/16	34	17	22-5/16	80.2	16-11/16	78.8	17-3/8	51-1/16	
Large	40	46-9/16	37-3/8	18-11/16	22-5/16	80.2	16-11/16	78.8	17-3/8	51-1/16
		49-15/16	40-13/16	20-3/8	22-5/16	80.2	16-11/16	78.8	17-3/8	51-1/16

Wind Baffle Dimensions for Preferred™ Series Units

Unit Size	AA	Unit Height	A (In.)	B (In.)	C (In.)	D (degrees)	E (In.)	F (degrees)	G (In.)	H (In.)
Medium	33	30	23-13/16	11-7/8	16	81.9	16-3/8	80.3	12-3/4	45-7/8
		33-7/16	27-3/16	13-5/8	16	81.9	16-3/8	80.3	12-3/4	45-7/8
		36-13/16	30-5/8	15-5/16	16	81.9	16-3/8	80.3	12-3/4	45-7/8
		40-1/4	34	17	16	81.9	16-3/8	80.3	12-3/4	45-7/8
		43-5/8	37-3/8	18-11/16	16	81.9	16-3/8	80.3	12-3/4	45-7/8
	48	40-13/16	20-3/8	16	81.9	16-3/8	80.3	12-3/4	45-7/8	
	34-3/16	23-13/16	11-7/8	22-5/16	80.2	16-11/16	78.8	17-3/8	51-1/16	
	37-5/8	27-3/16	13-5/8	22-5/16	80.2	16-11/16	78.8	17-3/8	51-1/16	
	41	30-5/8	15-5/16	22-5/16	80.2	16-11/16	78.8	17-3/8	51-1/16	
	44-7/16	34	17	22-5/16	80.2	16-11/16	78.8	17-3/8	51-1/16	
Large	40	47-13/16	37-3/8	18-11/16	22-5/16	80.2	16-11/16	78.8	17-3/8	51-1/16
		51-3/16	40-13/16	20-3/8	22-5/16	80.2	16-11/16	78.8	17-3/8	51-1/16



